

A Minimalist Approach to Argument Structure of Dholuo Concatenated Verbal Extensions

Dr. Erick Omondi Odero (PhD)*, Mr. Walter Ochieng Sande (MA)

Department of Languages, Linguistics & Literature, Rongo University

Email: erickodero@yahoo.com

DOI: 10.6007/IJARBSS/v7-i6/2950 URL: <http://dx.doi.org/10.6007/IJARBSS/v7-i6/2950>

Abstract

Verbs in Agglutinating languages, Dholuo included, have ability of accommodating derivative morphemes which get affixed to their roots. This affixation alters argument structure of the host verb thus changing the syntax and the semantics of the verb. These derivative morphemes because of their characteristics of extending verbs both syntactically and semantically are referred to as verbal extensions. The verbal extensions under investigation are the applicative, the locative, the reflexive, the reciprocal and the stative in their co-occurrent states. The incorporation of the co-occurrent Dholuo verbal extensions in a template of a verb, according to the principles of MP, causes the creation of derivational heads where syntactic and semantic features in the extended verb are checked. The semantic heads are created in configurations to provide sites where arguments introduced by Dholuo verbal extensions to the host verb are assigned their semantic roles through the merger of the head with the arguments. Data examined in this study was generated by the researchers who are themselves native speakers of Dholuo. In some instances however, consultations were made with other native speakers for cross-checking purposes. This study was motivated by the fact that the writers are Dholuo speaking linguists with in-depth interests in understanding the structure of Dholuo expressions from the linguists' perspective.

Keywords: In Situ, Valence, Concatenation, Valence, Merger, Checking, Argument And Local Domain.

1. Introduction

The term argument structure was developed around 1980 in American linguistics to render a concept that had long been known in European linguistics under the name valence. An argument structure has a component called argument. According to Trask (1993, p.20), an argument is a noun phrase (NP) or a prepositional phrase (PP) bearing a specific grammatical or semantic relation to a verb and whose overt or implied presence is required for well-formedness in structures containing that verb. He adds that specification of the number and types of arguments required for a verb in a sentence structure to be well-formed defines the argument structure of that verb. Subject and object phrases are the most frequently occurring arguments of verbal predicates with both grammatical and semantic functions in languages. Baker (1996) on the other hand, argues that argument structure is identified in a language in terms of syntactic roles such as, the subject and the object and in terms of semantic roles such

as agent, patient, theme, benefactive, experiencer, instrument, source and malefactive. Arguments are assigned roles with reference to the host verbs. Argument structure is therefore the definition of syntactic and semantic roles of an argument in relation to its predicate.

Dholuo argument structure is identified in terms of the syntactic roles of the subject and the object and in terms of the semantic roles an argument takes in relation to its host verb. Syntactically, Dholuo verbs are classified as either intransitive or transitive based on the number of arguments the verbs can host. The number of arguments defines the host verb's valence. The valence of a verb according to Tesnière (1959) is its inherent relationality that allows it to govern a particular number of arguments. Brown and Miller (1996, p.359) in support of this argument, look at valence as the capacity of a verb to take a specific number of arguments (noun or prepositional phrase positions). Intransitive verbs are therefore classified as mono-valent since they take one argument-the subject. Monotransitives are classified as di-valent because they host two arguments: the subject and the object. Ditransitive verbs on the other hand, are called tri-valent since they take three arguments-the subject and two object arguments (direct and indirect objects).

Dholuo unextended verbs are usually encapsulated in a verbal complex comprising a subject prefix followed by a verb root after which comes the indicative mood suffix and an object suffix in that order (Tucker, 1994). Example (1) shows a verb root having both prefixes and suffixes.

1) *gi-mos-o-u*

3pIS-greet-IND-2pIO

They are greeting you.

The prefix *gi* marks the subject of the verb and the suffix *u* is the object of the verb. Based on the example (1), the verb *moso* (to greet) has two arguments; the subject and the object. This gives the verb a valence of two.

Agglutinative languages, Dholuo included, have morphological alterations in their verbs marked by additional suffixes (extensions) affixed to roots of these verbs. These extensions are in most cases marked by derivational morphemes (Hyman, 2007 & Waweru, 2011). The verb *moso* in the example (1) above can morphologically be reshaped by affixation of an extension to its root. Consider example (2).

2) *gi-mos-o-u-n-a*

3pIS-greet-IND-2pIO-APPL-1sgO

They have greeted on my behalf.

The verb *moso* in the example (2) above has been extended by affixation of an applicative morpheme *n*. Introduction of this morpheme to the matrix of this verb alters the argument structure of the verb by introducing an applied object marked by the bound morpheme *a*. This increases the number of arguments that the verb subcategorises for from initial two to three. The argument introduced is also assigned a semantic role of benefactive by the host verb since it benefits from the action performed by the agent *gi*.

Verbal extensions relevant to this study are: applicative, reflexive, reciprocal, stative and locative. These extensions, as shown in example (2), have effects of altering argument structures of their host verbs by introducing their arguments to the matrix of the host verbs

hence a change in valencies of Dholuo verbs they are affixed to. These extensions have ability of co-occurring, that is, they simultaneously get affixed to the host verb. The morphology of Dholuo extended verbs allows co-occurrences of these extensions of up to a maximum of three. As these concatenations occur, argument structure of a host verb is altered either by increasing or reducing valence of the host verb and assignment of semantic roles to arguments introduced by the co-occurrent extensions.

2. Minimalist Program

Minimalist Program (MP) is the latest development of the Generative enterprises. In the MP, structures are represented and generated to account for language phenomena using the smallest set of devices for the linguistic system to be as economical as possible (Chomsky, 1995). According to Chomsky's (2000, 2005) remarks, MP is not a theory but a set of guidelines that should ideally lead to a maximal projection of the theoretical apparatus used to describe and account for linguistic data. These apparatuses include the movement, the checking, the numeration, the greed and the merger each with its significant role in the analysis of linguistic data.

Morphology of Dholuo verbs constitutes morphological features; the subject agreement (AGRs), the object agreement (AGRo) and the aspect (ASPE). The AGRs and AGRo project to subject agreement phrase (AGRsP) and object agreement phrase (AGRoP) respectively. The number of heads in a tree is dependent on the structure of the construction to be analyzed by the MP. Items that constitute a sentence structure have got features. The number of heads and specifiers in a syntactic tree is feature driven. These features are lexical or morphological. Every feature in a construction according to the MP must be checked at its respective head for its interpretation. The introduction of a verbal extension to a Dholuo verb initiates the creation of a derivational head of that particular extension in an MP tree where the verb gets its interpretation for that particular extension by checking its features. For semantic features checking and semantic interpretation of arguments introduced by extensions, thematic heads are created in MP trees. Arguments for the extensions are assigned semantic roles through their merger with the semantic heads. Schroeder (2008) points out that feature checking requires all languages to have verb movement, that is, all languages move their verbs to the inflectional nodes (heads) and NPs are moved to the specifier of AGRsP and AGRoP for feature checking. Baker (1988) notes that some morphological processes like the verb derivations influence syntax. These processes produce constructions that have more than one internal argument. The morphological affixes that produce these arguments project their own functional heads with features that have to be checked in the course of derivation.

These heads are reflected in the MP basic sentence structure in figure 1.

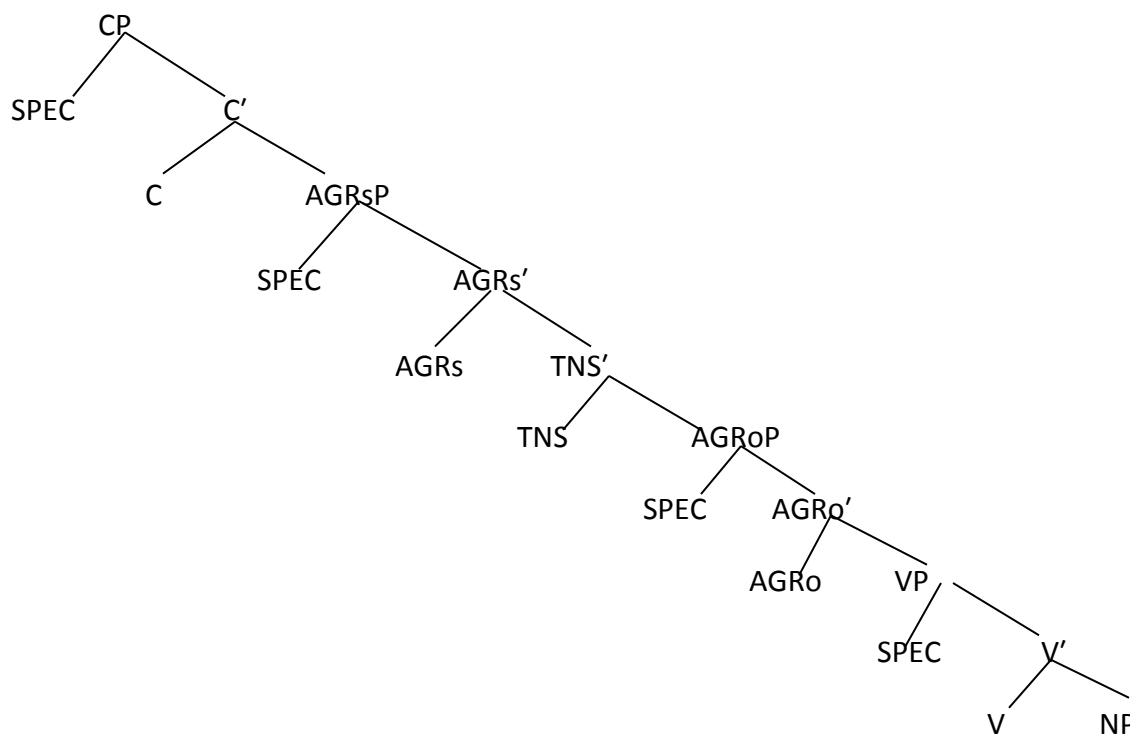

Figure 1: The Basic Minimalist Program Structure (Chomsky, 1993)

3. Research Methodology

A descriptive research design was used in this study. The design involved a description of observed patterns of morphemes in Dholuo verbs. Data examined in this study was generated by two of the researchers, native speakers of Dholuo. Consultations were also made with other native speakers for cross-checking purposes.

4. Argument Structure of Dholuo Verbs with Multiple Verbal Extensions

In the multiple occurrence of Dholuo verbal extension, each and every participant extension introduces its argument to their host verb. These arguments take syntactic positions in the verbal matrix. The occupation of syntactic position by these arguments causes their assignment of semantic roles by their host verbs (Sande, 2016).

This section discusses the argument structure of Dholuo verbs with multiple verbal extensions. The section looks at both the semantic and the morphosyntactic alterations that these co-occurrent extensions cause in the structures of their host verbs. These features are analysed within a framework of MP.

4.1 Argument Structure of Dholuo Verbs with Two Extensions

Whenever Dholuo verbal extensions co-occur in combinations of two, each extension causes changes in the argument structure of their host verb. These changes are both syntactic and semantic. The syntactic change is based on the effect of the extensions on the valence of the host verb. Because the arguments¹ of these extensions are assigned semantic roles by the host verb, the meaning of the host verb changes as a result.

4.1.1 The Applicative and the Locative

The applicative² extension can co-occur with the locative³ extension in a Dholuo construction. The morphemes *-n* and *-e* mark the applicative in that order. Co-occurrence of these extensions increases the valence of a host verb by increasing the number of arguments of the verb since the two extensions are valence increasing operations. Consider the unextended verb in example (3).

- 3) *o-se-many-o_nyathi*
3sgS-perf-look-IND_child
He/she/it has looked for a child

The verb in the example (3) above subcategorises for two arguments *o* (subject) and *nyathi* (object occurring as a free morpheme). An attachment of the two extensions to the verb gives rise to a different structure as shown in example (4).

- 4) *o-se-many-o-n-wa-e_nyathi*
3sgS-perf-look-IND-APPL-1pIO-LOC_child
He/she/it has looked for a child for us at a place.

The verb *manyo* in the example in (4) above is used transitively. Dholuo transitive verbs subcategorize for the subject and object arguments. The attachment of both the applicative and the locative extensions to this verb alters the argument structure of the verb by introducing the applied argument *wa* and the locative argument *e* to the verb. The locative argument in Dholuo as shown in the example (4) above is oblique in nature - it takes a PP form. The attachment of these extensions to the verb increases the number of arguments from two to three, namely the subject argument *o*, the applicative argument *wa* and the locative argument *e*. The two arguments are assigned the semantic roles of benefactive and locative respectively. The applied argument *wa* is the beneficiary of the action denoted by the verb *manyo* (to look for) and the locative argument *e* indicates the place where the action of preaching happens.

¹ Arguments introduced by extensions within matrices of Dholuo verbs can get assigned semantic roles depending on the semantic relations built between these arguments and the action denoted by their host verbs

² The applicative extension indicates that the action is applied on behalf of, towards or with regard to some object.

³ Locative denotes a place where an action takes place. Martin and Müller (2011) have classified the locative extension under types of applicative extension. Waweru (2011) categorizes the locative extension as a type of the applicative because it is marked by the same morpheme in Gikuyu. In Dholuo, the applicative and locative extensions occur as distinct extensions marked by different morphemes.

In the co-occurrence of the applicative and the locative extension, each and every extension introduces its argument to the host verb which is given its own derivational head in the MP tree for feature checking and interpretation. See the syntactic configuration of the example (4).

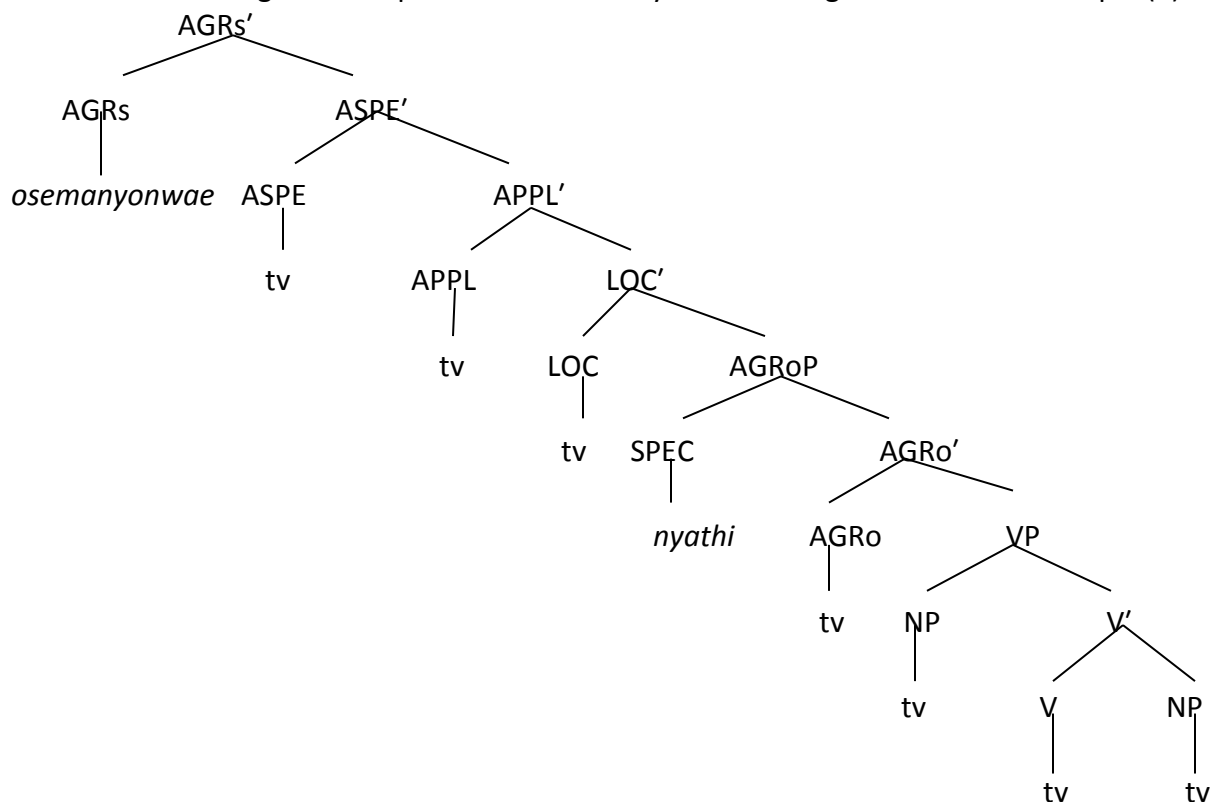

Figure 2: Syntactic Configuration of the Co-occurrent Applicative and Locative Construction, *osemanyonwae nyathi*

The verb makes movements, as shown in figure 2 above, to both the functional and the derivational heads for features checking. The verb first moves from within the verb phrase (VP) domain to object agreement/object agreement bar (AGRo/AGRo') for the checking of object agreement feature in the applicative argument *wa*. From here the move proceeds to locative/locative bar (LOC/LOC') head for the locative feature checking with the locative argument *e*. It then moves to applicative/applicative bar (APPL/APPL') node where applicative feature checking happens with its argument *wa*. For perfective aspect feature checking, the verb moves to ASPE/ASPE' node. It is from here that the verb makes its final move to subject agreement/subject agreement bar (AGRs/AGRs') node for subject agreement feature checking. The NP *nyathi* which is the direct object argument to the verb assigned a case feature, makes its own movement from inside the VP to specifier/object agreement phrase (SPEC/AGRoP) node for accusative case feature checking.

For semantic features checking and the assignment of the semantic roles to the arguments in the construction in example (4) above, semantic heads are created, as shown in figure 3.

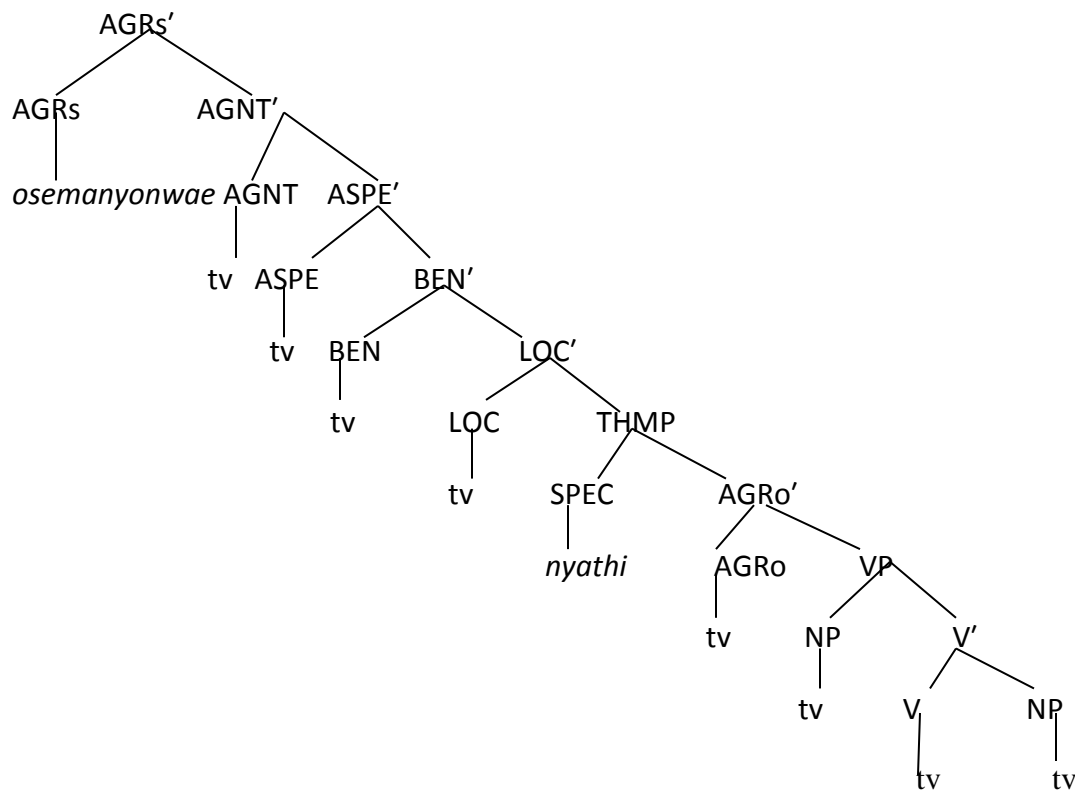

Figure 3: Semantic Configuration of the Co-occurrent Applicative and Locative Construction, *gisewitonwae kidi*

The verb, as figure 3 above shows, moves via AGRo/AGRo' from within the VP to the semantic head LOC/LOC' where the locative argument through its merger with the semantic head is assigned the semantic role of locative. The checking of the semantic role feature-locative happens at this node. For assignment of the semantic role of recipient to the applicative argument *wa*, the verb moves to the benefactive/benefactive bar (BEN/BEN') node. It is also at this head where the semantic role feature-benefactive is checked for the applicative argument. The verb then moves to aspect/aspect bar (ASPE/ASPE') head where perfective aspect feature is checked. The verb finally makes a movement to agent/agent bar (AGNT/AGNT') head where the semantic role feature-agent is checked after the assignment of this role to the subject argument *o*.

The NP *nyathi* also makes its own movement from NP, a position within VP to specifier/theme phrase (SPEC/THMP) node to satisfy its own semantic need by checking the accusative case feature in the NP.

4.1.2 The Reflexive and the Locative

The reflexive⁴ extension co-occurs with the locative extension to form a construction morphologically containing both the reflexive and the locative morphemes. Dholuo reflexive extension is marked by the morpheme *-r*. Upon extension of the verb with the two suffixes, the reflexive and the locative arguments are introduced. Consider example (5).

- 5) *gi-lwok-o-r-e-e*
 3pIS-bathe-IND-RFL-pIO-LOC

They are bathing themselves at a place.

The verb *lwoko* (to bathe) is a monotransitive verb. Dholuo monotransitive verbs host two arguments, the subject and the object arguments. As shown in the example in (5) above, the attachment of the reflexive suffix to the verb *lwoko* introduces the reflexive argument *e* maintaining the number of arguments at two namely, the subject argument *gi* and the reflexive argument *e*. The subject argument and the reflexive arguments are co-referential in this case. The attachment of the locative suffix to this verb introduces a third argument-the locative argument *e* thus increasing the valence of the host verb from two to three. The reflexive argument can get assigned the semantic roles for example those of benefactive and experiencer. For instance the reflexive argument *e* in example (5) above is a benefactor of bathing hence assigned the semantic role of beneficiary. When syntactically analyzed under the MP theory, the construction in (5) above creates an MP tree as shown in figure 4 below.

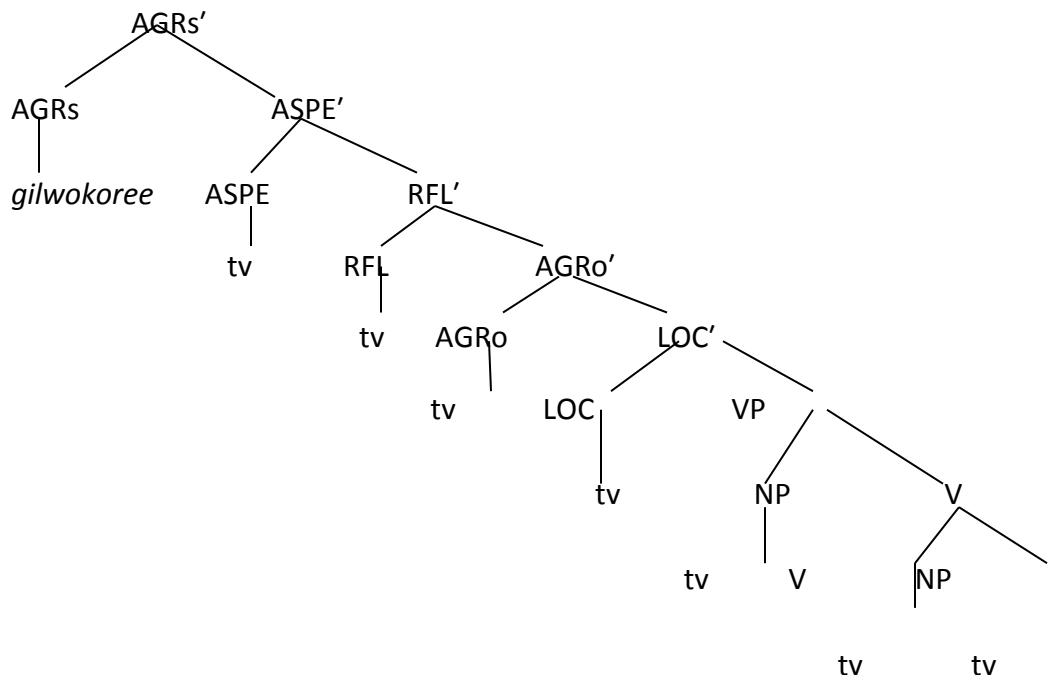

Figure 4: Syntactic Configuration of the Co-occurrent Reflexive and Locative Construction, *gilwokoree*

⁴ Reflexive arguments are sometimes called anaphors since they obligatorily get their meanings from the subject argument called antecedent. Antecedents are selected by the reflexive from the local domain which is normally the minimal clause or NP containing the reflexive and accessible antecedent (Chomsky, 1981).

The attachment of the locative and the reflexive suffixes to the verb in figure 4 above introduces the locative and reflexive arguments which have derivational features to be checked. This verb first moves from the VP domain to LOC/LOC' where the semantic role feature-locative is checked with the locative argument *e*. The verb then moves to AGRO/AGRO head for object agreement feature checking. For reflexive feature checking with the reflexive argument *e*, the verb moves to reflexive/reflexive bar (RFL/RFL') node. The verb then makes a movement to check its progressive aspect feature at ASPE/ASPE' node. The final movement is made by the verb to AGRs/AGRs' head for checking of the subject agreement feature.

The MP analysis of semantic features of the arguments of the verb in the construction in (5) above produces an MP tree, seen in figure 5 below.

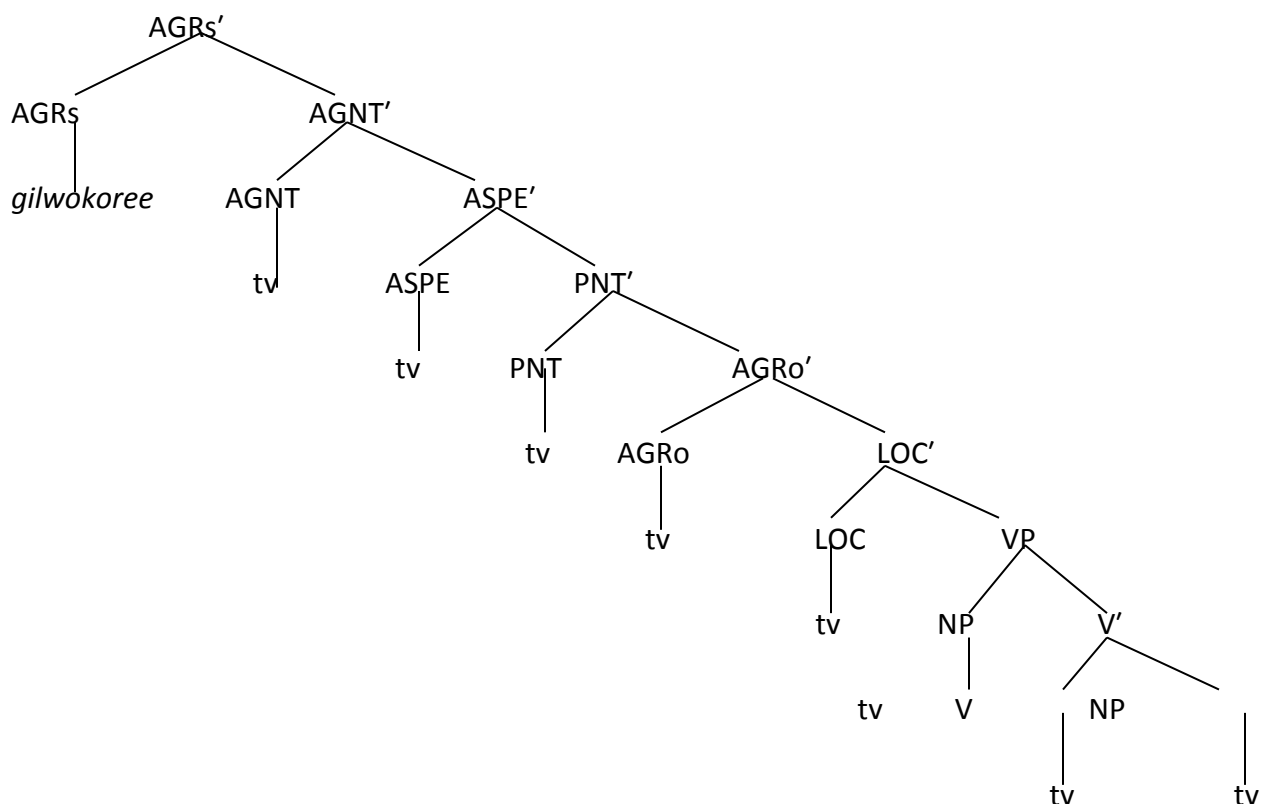

Figure 5: Semantic Configuration of the Co-occurrent Reflexive and Locative Construction, *gilwokoree*

The derived verb, as shown in figure 5 above, moves from within the VP to the semantic head locative/locative bar (LOC/LOC') where locative argument *e* is assigned the semantic role of locative through merger. Thereafter, the semantic role feature-locative is checked with the locative argument *e*. From here, the verb moves to the patient/patient bar (PNT/PNT') node where the reflexive argument is assigned its semantic role of patient. The role assignment is followed by the semantic role feature-patient checking at the same node. The move finally

proceeds to AGNT/AGNT' node for the assignment of the semantic role to the subject argument *gi*. This is followed by the checking of the semantic role feature-agent.

4.1.3 The Reflexive and the Applicative

The reflexive extension co-occurs with the applicative extension giving rise to a construction with both the applied and the reflexive arguments. The attachment of the reflexive suffix *-r* to a host verb introduces a reflexive argument. Just as the attachment of applicative extension *-n* introduces an applied argument. The reflexive extension, as discussed in section 4.1.2, maintains the number of arguments of its host verb unlike the applicative extension which increases the number of arguments. These arguments are assigned both syntactic and semantic roles by the host verb. For illustration consider example (6).

- 6) *a-neg-o-r-a-n-i*
1sgS- kill-IND-RFL-1sgO-APPL-2sgO
I am killing myself for you.

The verb *nego* in example (6) above is a monotransitive verb with a valence of two. The attachment of the reflexive suffix to this verb *nego* introduces the reflexive argument *a*. Despite the introduction of the reflexive argument *a* to the matrix of the verb, the valence is maintained at two – the usual valence for a monotransitive verb. This number of arguments increases from two to three up on the attachment of the applicative to the verb since the applicative extensions adds the applicative argument *i* to the verb.

In this co-occurrence, reflexive arguments can get assigned semantic roles for instance of patient and experiencer. Consider examples below.

- 7) (a) *u-wang'-o-r-e-n-a*
2plS-burn-IND-RFL-plO-APPL-1sgO
You are burning yourselves for me.

- (b) *wa-sand-o-r-e-n-u*
1plS-mistreat-IND-RFL-plO-APPL-2plO
We are mistreating ourselves for you.

The reflexive argument *e* in example (7a) above is assigned the semantic role of patient as it receives the action of burning. In the construction in (7b) above, the reflexive argument *e* is assigned the semantic role of experiencer since it feels the impact of mistreatment. Applied object arguments in the co-occurrence of the reflexive and the applicative extensions also take the semantic role of benefactive, as shown in example (8).

- 8) *wa-goy-o-r-e-n-i*
1plS-fight-IND-RFL-plO-APPL-2sgO
We are fighting ourselves for you.

The applied argument *i* in the example (8) above benefits from the action of the other party fighting thus assigned the semantic role of benefactive.

The reflexive and the applicative arguments for example in the construction in (6) above get assigned semantic roles at their semantic heads through the merger of the arguments with their respective heads, as shown in figure 6 below.

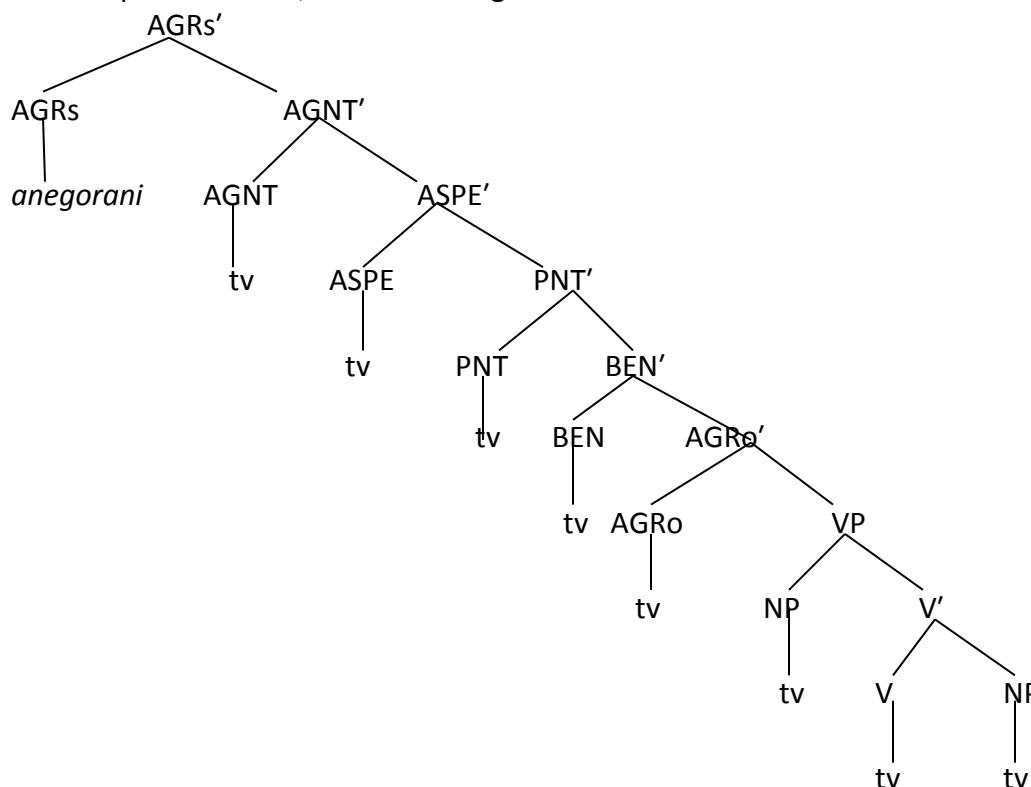

Figure 6: Semantic Configuration of the Co-occurrent Reflexive and Applicative Construction, *anegorani*

It is at the three semantic heads in figure 6 above that the subject; the applicative and the reflexive arguments get assigned their semantic roles through the merger of the arguments with their respective semantic heads. These happen after the movement of the verb to BEN/BEN' where the merger between the argument and the semantic head assigns the applied argument a benefactive role. This semantic feature-benefactor is also checked at this head. At the PNT/PNT' head, the merger process ensures that reflexive argument get assigned patient role. The semantic feature role-patient is checked at this node. From those heads, the verb moves to AGNT/AGNT' node for the assignment of the semantic role to the subject argument *a*.

4.1.4 The Reciprocal and the Applicative

The extension of a Dholuo verb by both the reciprocal⁵ and the applicative morphemes alters the argument structure of their host verb by introducing both the applied and the reciprocal arguments to the verbal matrix. Consider example (9).

- 9) *wa-gwey-o-r-e-n-u*
1pIS-kick-IND-REC-pl-APPL-3pIO
We are kicking each other for you

The verb *gweyo* is a di-valent verb. A di-valent verb hosts two arguments, the subject and object arguments. The attachment of the reciprocal suffix to the verb *gweyo* introduces the reciprocal argument *e* hence the two arguments: the subject argument *wa* and the reciprocal argument *e*. This operation therefore maintains the valence of the verb at two. The applied object argument *u* in the extended verb in the example in (9) above is as a result of the affixation of the applicative suffix to the verb. The introduction of this argument increases the valence of the verb from two to three.

The semantic role of patient or recipient can be assigned the reciprocal arguments in the co-occurrence of the reciprocal and the applicative extensions. The common semantic role assigned applied objects in applicativised Dholuo verbs is benefactive role. Consider example (10).

- 10) *wa-kay-o-r-e-ne⁶-gi*
1pIS-bite-IND-REC-plO-APPL-3pIO
We are biting each other for them.

The argument *e* in the example (10) above undergoes the action of biting hence assigned the semantic role of recipient. The applied object argument *gi* in this co-occurrence takes the semantic role of benefactive.

The inclusion of the reciprocal and the applicative suffixes in the verbal matrix in the construction in (10) above, introduces derivational features whose features checking configures an MP tree shown in figure 7 below.

⁵ The difference between Dholuo reciprocal and reflexive extensions is that the reciprocal extension in Dholuo only occurs with plural subject prefixes because the antecedent has to be plural. It cannot take the singular subject suffixes as do the reflexives since there will be no agreement in number with the anaphor.

⁶ The vowel /e/ is epenthesized between the applicative suffix and the consonant /g/ to break up the consonant cluster to make the two consonants contrast and more distinct.

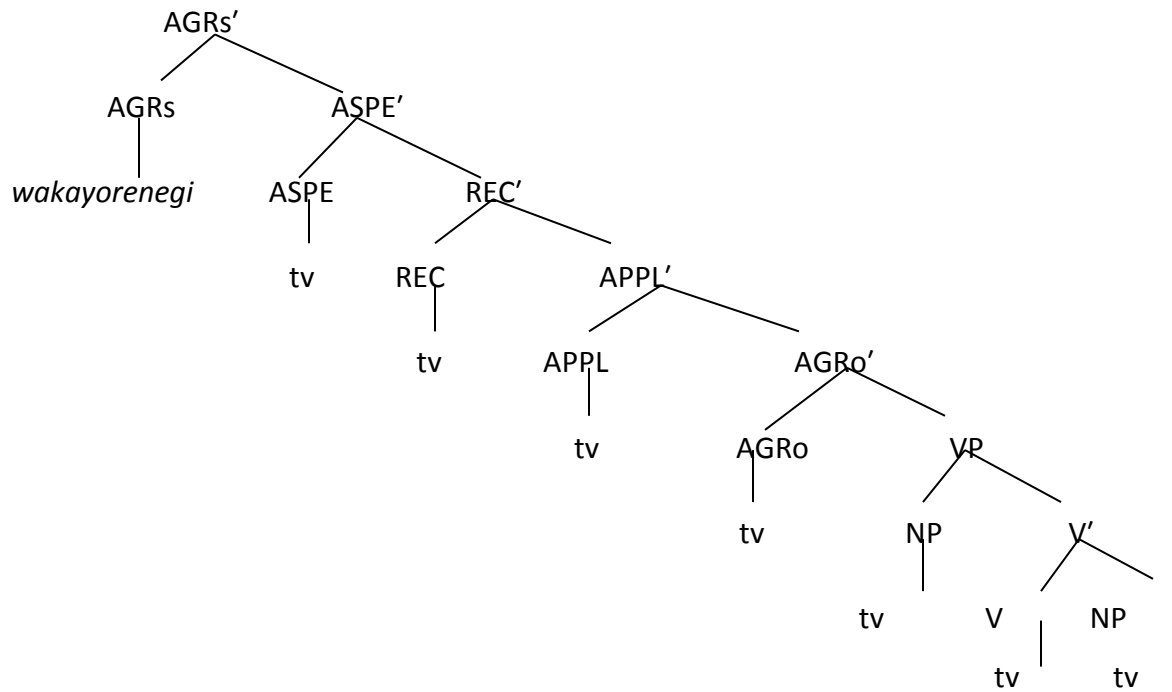

Figure 7: Syntactic Configuration of the Co-occurrent Reciprocal and Applicative Construction, *wakayorenegi*

The verb first moves from inside the VP to AGRO/AGRo' node for the checking of the object agreement feature. The move of the verb proceeds to APPL/APPL' node to check for the applicative feature with the applicative argument *gi*. From here, the verb moves to REC/REC' node where the reciprocal feature is checked with the reciprocal argument *e*. The verb then moves to ASPE/ASPE' for aspectual feature checking. The final move is made by the verb to AGRs/AGRs' node for subject agreement feature checking.

The semantic role feature checking in the construction in (10) above happens at semantic heads where the reciprocal and applicative arguments get assigned semantic roles through the merger process. Consider figure 8 below for the semantic configuration of the construction in example (10).

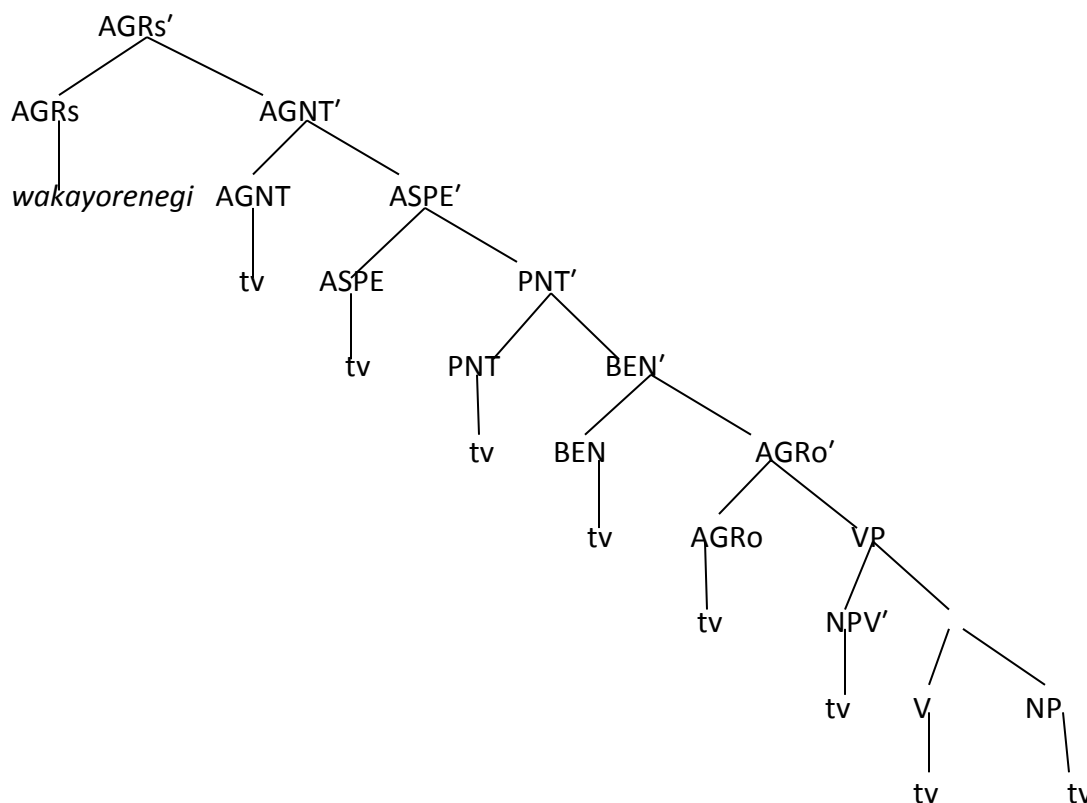

Figure 8: Semantic Configuration of the Co-occurrent Reciprocal and Applicative Construction, *wakayorenegi*

The verb, in figure 8 above, moves from within the VP domain via AGRo/AGRo' node to BEN/BEN' for semantic role feature-benefactive checking with the applied argument *gi*. This occurs after this argument is assigned the semantic role of benefactive at this head. The movement proceeds to PNT/PNT' head where the reciprocal argument is assigned the semantic role of patient and its semantic role feature-patient is checked. For the assignment of the semantic role of agent to the subject argument *wa*, the verb moves to AGNT/AGNT' node followed by the checking of the semantic role feature-agent.

4.1.5 The Stative and the Locative

The co-occurrence of the stative and the locative extensions introduces both stative and locative arguments in the construction respectively, as shown in example (11).

- 11) *u-thiedh-o-r-e-e*
 2pIS-treat-IND-STV-2pIO-LOC
 You are treatable at/in a place.

The stative⁷ extension makes a di-valent verb a mono-valent one. For example, in the construction in (11) above, the stative extension makes the di-valent verb *thiedho* a mono-valent by introducing the stative argument *u* as the only argument. The attachment of the locative suffix to the verb *thiedho* introduces the locative argument *e* thus increasing the number of arguments that had already been reduced through stativisation from one to two in the host verb. The arguments are the stative argument *u* and the locative argument *e*.

The semantic roles of theme and locative are assigned stative and locative arguments respectively in the co-occurrent construction in example (11) above.

The MP analysis of the syntactic features of the stative construction in (11) above results into an MP tree as in figure 9 below.

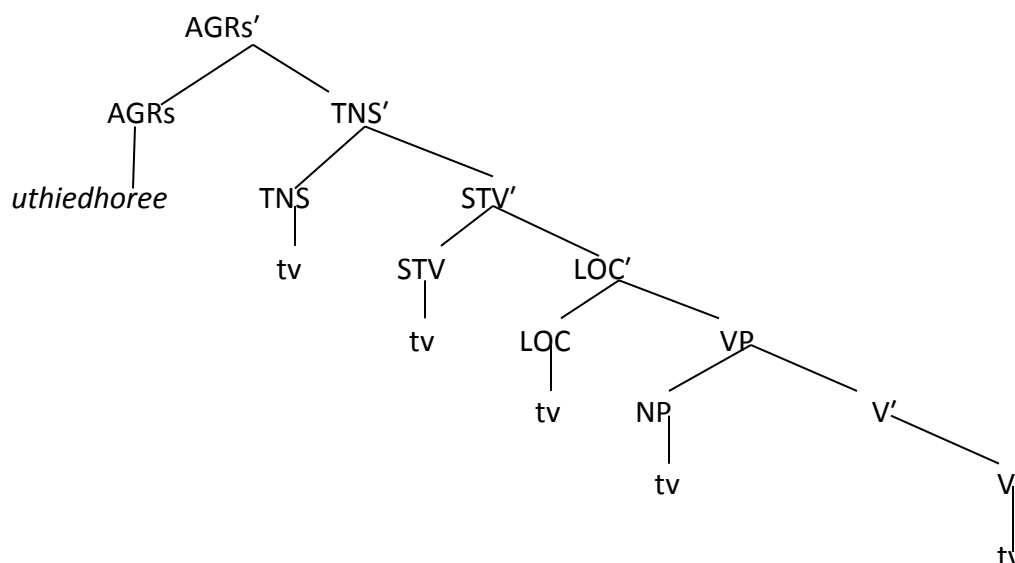

Figure 9: Syntactic Configuration of the Co-occurrent Stative and Locative Construction, *uthiedhoree*

The verb makes movement from within the VP domain to different heads in the tree in figure 9 above to satisfy its own functional and derivational features. The verb first moves to LOC/LOC' node where the locative feature is checked with its argument *e*. This is followed by the checking of the stative feature at the stative/stative bar (STV/STV') node. For tense feature checking, the

⁷In Dholuo, as in other languages, the stative suffix derives a one participant clause from a basic underived two-participant clause. Therefore, in terms of argument structure, the result of stativisation is expected to be intransitive. It follows that neither an overt object nor an object marker should be possible in a stative construction. However, in Dholuo an object marker is present. This object marker is non-argumental; it is obligatorily retained here only to define the scope of in situ (Sande, 2016). In situ is the local domain within which the object marker and the subject fall.

verb moves to tense/tense bar (TNS/TNS') node. The final move is made by the verb to AGRs/AGRs' for subject agreement feature checking.

For semantic role feature checking and assignment of semantic roles to the arguments, semantic heads are created, as seen in figure 10.

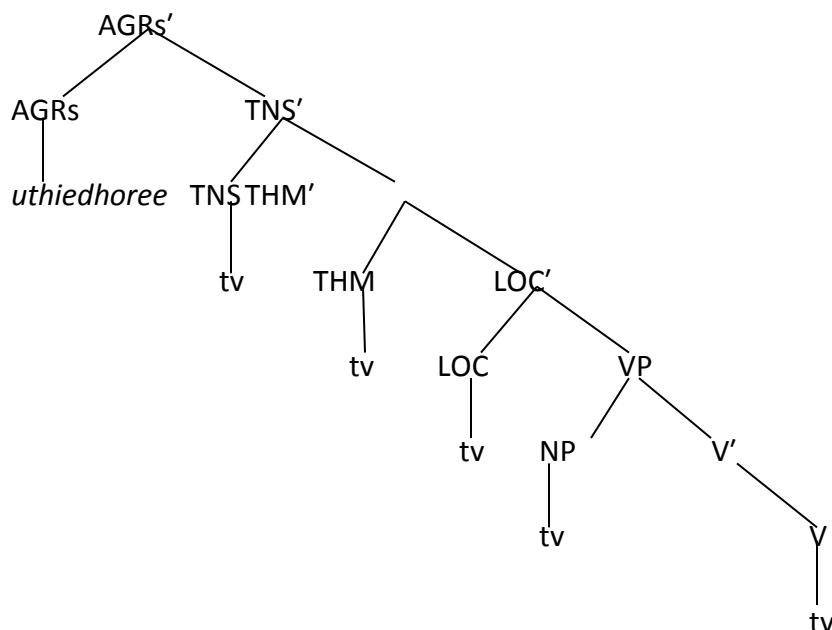

Figure 10: Semantic Configuration of the Co-occurrent Stative and Locative Construction, *uthiedhoree*

The verb *thiedho* first moves from within the VP domain to LOC/LOC' head where the semantic role feature-locative is checked with the locative argument *e*. This happens after the assignment of the semantic role of locative to this argument. The verb then makes a move to another semantic head, theme/theme bar (THM/THM') where the semantic role feature-theme is checked with the stative argument *u* after the assignment of the semantic role of theme to the stative argument.

4.1.6 The Stative and the Applicative

In the co-occurrence of the stative and the applicative, the stative extension introduces a stative argument which occupies the subject slot while the applicative extension introduces the applied object argument, as shown in example (12).

- 12) *gi-som-o-r-e-ne-u*
 3pIS-read-IND-STV-3sgO-APPL-2pIO
 They are readable for you.

The verb *somo* (to read) in the example in (12) above is a transitive verb. The affixation of the stative suffix reduces the number of arguments of the verb from two to one namely, the subject argument *gi*. The attachment of the applicative suffix to the host verb *somo* alters the argument structure of the verb by introducing the applicative argument *u* thus increasing the number of arguments from one to two, that is the subject argument *gi* and the applicative argument *u*. The semantic roles of theme and benefactive are assigned stative and applied arguments respectively as shown in the co-occurrent construction in example (13).

13) *u-ting'-o-r-e-n-a*
 2pIS-carry-IND-STV-2pIO-APPL-1sgO
 You are portable for me.

The stative argument *u* in the example (13) above can get moved hence assigned the semantic role of theme while the applied object argument *a* is assigned the semantic role of benefactive as it benefits from the portability of the stative argument. For semantic feature checking, thematic heads THM/THM' and BEN/BEN' for example in the construction (14) below are created for the checking of their features with their arguments after the assignment of the semantic roles of theme and benefactive to the stative and applicative arguments respectively.

14) *gi-som-o-r-e-n-u*
 3pIS-read-IND-STV-plO-APPL-2pIO
 They are readable for you.

Consider semantic configuration in the figure 11 below.

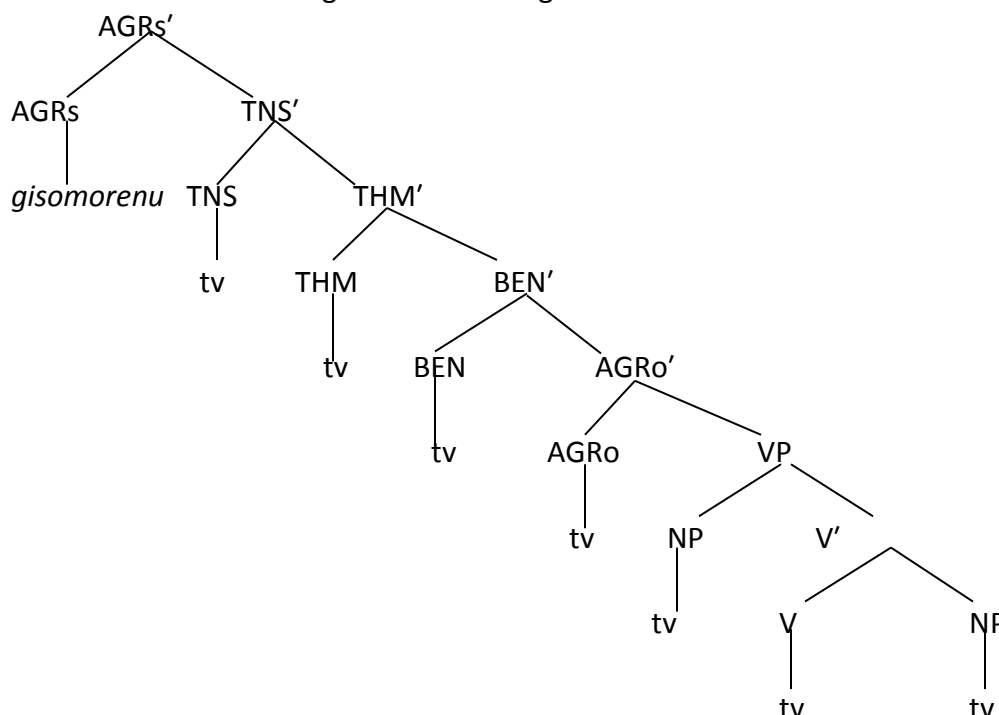

Figure 11: Semantic Configuration of the Co-occurrent Stative and Applicative Construction, *gisomorenu*

The verb moves from within the VP domain via AGRo/AGRo' node to BEN/BEN' node where through merge process, the applicative argument *u* gets assigned the semantic role of benefactive after which the semantic role feature-benefactive is checked. From there the verb moves to THM/THM' node where the stative argument *gi* gets assigned the semantic role of theme. It is also at this node where the semantic feature-theme is checked.

4.2 Argument Structure of Dholuo Verbs with Three Verbal Extensions

As discussed earlier, Dholuo verb morphology allows co-occurrence of its extension up to three. The co-occurrence of three Dholuo verbal extensions has effects on the argument structure of their host verb in terms of the number of arguments the host verb acquires after the attachment of these extensions. The arguments of these co-occurrent extensions are assigned semantic roles by their host verb. These changes are discussed below.

4.2.1 The Reciprocal, the Applicative and the Locative

As discussed in section 4.1.1, the co-occurrence of the reciprocal and the applicative extensions introduce both reciprocal and applied arguments. The locative argument in this co-occurrence introduces a locative argument. For illustration consider example (15).

15) *gi-gwedh-o-r-e-n-i-e*

3pIS-bless-IND-REC-pIO-APPL-2sgO-LOC.

They are blessing each other in/at a place for you.

In the co-occurrence of the reciprocal and the applicative extension, the reciprocal maintains the valence of the host verb while the applicative increases the valence of the verb. In the example in (15) above, the reciprocal suffix introduces the reciprocal argument *e* to the monotransitive verb *gwedho* thus maintaining the number of arguments of the verb at two, that is, the subject argument *gi* and the reciprocal argument *e*. The attachment of the applicative suffix to this verb introduces a new argument, the applied argument *i* increasing the number of arguments from two to three. The third extension, the locative extension also increases the number of arguments by introducing the locative argument *e*. This increases the number of arguments of the host verb from three to four. The semantic roles assigned reciprocal, applicative and locative arguments in this co-occurrence are similar to those they get assigned in the double occurrence of these extensions. Reciprocal arguments in this co-occurrence can take the semantic roles of patient and experiencer, as discussed in section 4.1.4. Consider examples (16a) and (16b).

16) (a) *wa-pad-o-r-e-n-i-e*

1pIS-slap-IND-REC-pIO-APPL-2sgO-LOC

We are slapping each other at/in a place for you.

(b) *gi-boy-o-r-e-n-u-e*

3pIS-wrap-IND-REC-pIO-APPL-2pIO-LOC

They are wrapping each other at/in a place for you.

The reciprocal argument *e* in the example (16a) above receives the action of slapping hence assigned the semantic role of patient while that in (16b) is assigned the semantic role of experiencer since feels the effect of wrapping among the participants.

In this co-occurrence, the applicative arguments can get assigned the semantic role of benefactive while the locative arguments are assigned the semantic role of locative as they do in the double occurrence of these extensions, as discussed in sections 4.1.2 and 4.1.4 respectively and shown in example (17).

17) *u-kend-o-r-e-n-a-e*

2pIS-marry-IND-REC-plO-APPL-1sgO-LOC

You are marrying each other at/in a place for me.

In the example (17) above, the applicative argument *a* is the beneficiary of the action of marrying thus assigned the semantic role of benefactive and the locative argument *e* shows the place where marriage is taking place hence assigned the semantic role of locative.

The MP analysis of the syntactic features in the construction in (15) above creates an MP tree with heads whose number is determined by the features to be checked in the construction. Consider figure 12 below.

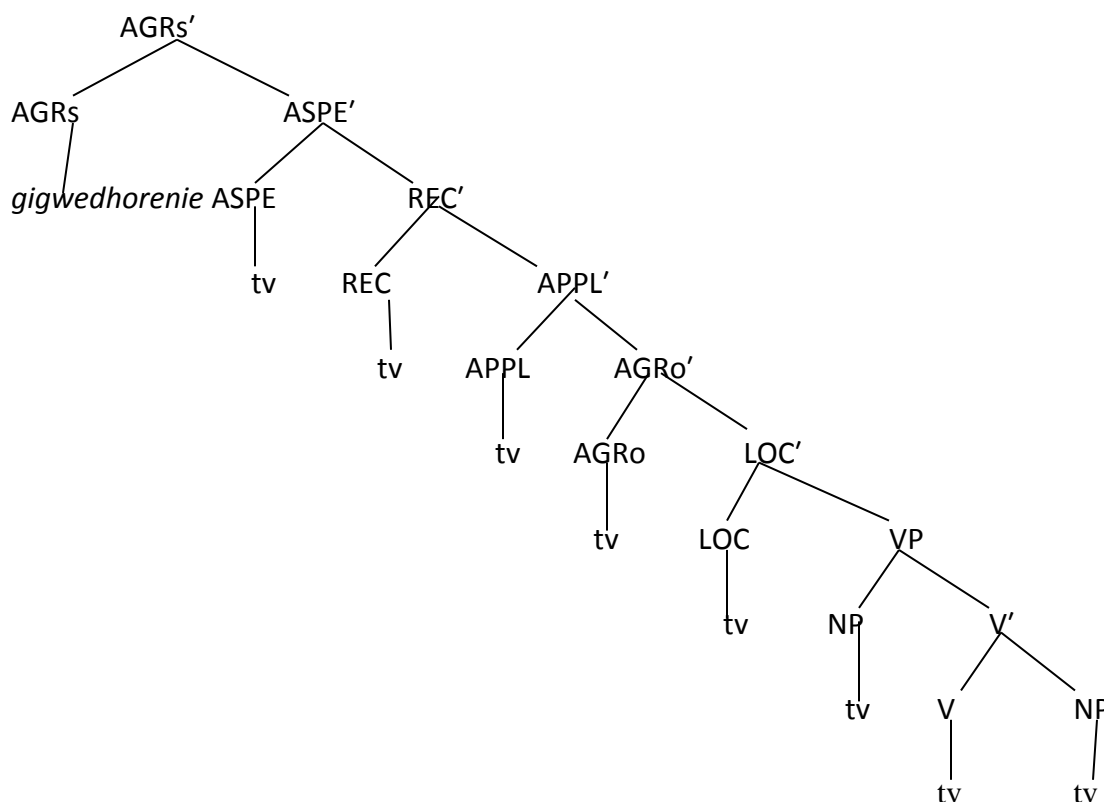

Figure 12: Syntactic Configuration of the Co-occurrent Reciprocal, Applicative and Locative Construction, *gigwedhorenie*

As shown in figure 12, the verb first makes its movement from within the VP domain to LOC/LOC' to check for the locative feature with the locative argument *e*. The movement proceeds to AGRo/AGRo' where the object agreement features in both the reciprocal and the

applicative arguments are checked. The next move is made by the verb to APPL/APPL' head where the applicative feature with the applicative argument *i* is checked. The verb then moves to REC/REC' node where the reciprocal feature with the reciprocal argument *e* is checked. For aspectual feature checking, the verb moves to ASPE/ASPE' node. The movement ends at the AGRs/AGRs' node for subject agreement feature checking.

For semantic feature checking and semantic role assignment to the arguments of the three extensions in the construction in (15) above, semantic heads are created, as seen in figure 13.

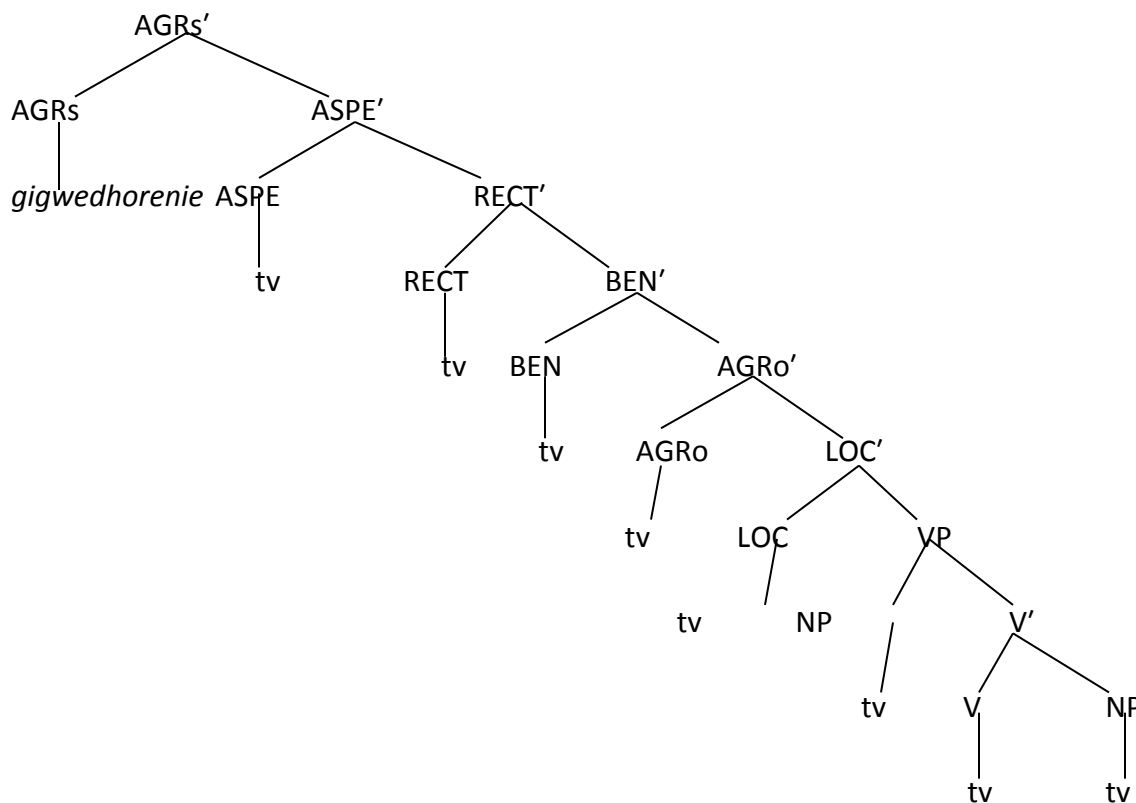

Figure 13: Semantic Configuration of the Co-occurrent Reciprocal, Applicative and Locative Construction, *gigwedhorenie*

The verb first moves from the VP domain to LOC/LOC', where the locative argument *e* gets assigned the semantic role of locative. The semantic role feature-locative is also checked at this node. From there the verb makes its movement to AGRO/AGRO' node for the checking of object agreement features in both the applicative and the reciprocal arguments. From there, the move proceeds to BEN/BEN' node where the applicative argument *i* is assigned the semantic role of benefactive after which the semantic role feature-benefactive is checked. The final semantic role assignment and checking of the semantic role feature happens at RECT/RECT' node where the reciprocal argument *e* is assigned the semantic role of recipient followed by the checking of semantic role feature-recipient.

Other possible co-occurrence of three extensions in Dholuo includes the reflexive, the applicative and the locative combination and the stative, the applicative and the locative co-occurrence. In these combinations, the arguments introduced to host verb template by the extensions alter argument structure of the verb by increasing or reducing the valence of the verb and these arguments get assigned semantic role the same way it happens in the combination discussed in section 4.2.1. These semantic roles are dependents on the semantic of the host verbs. In the MP analysis, these co-occurrences undergo the same process as displayed by the combination in section 4.2.1.

5. Conclusion

As far as the concatenated Dholuo verbal extensions are concerned, the discussion in this article shows that these extensions have effect of altering the argument structures of extended Dholuo verbs once they get affixed to the verbs. The applicative and locative extensions for instance introduce new arguments to their host verbs, the applied object argument and the locative argument respectively thus altering the argument structure of the host verb by increasing the number of arguments. The reflexive and the reciprocal maintain the valence of host verbs. The reflexive and reciprocal arguments introduced within a host verb's matrix are assigned semantic roles dictated by the semantics of the verb. For the stative extension the valence of a host verb is reduced for instance, when this extension occurs with a monotransitive or ditransitive verb, both the monotransitive and the ditransitive verbs change to intransitive ones which subcategorises for one argument, the subject argument. The morpheme that occurs in a stativised verb in an object slot is non-argumental. It is obligatorily retained in stativised constructions to define the scope of in situ. This extension does not operate with the intransitive verb. In terms of semantic role assignment, these arguments in their multiple occurrences can be assigned varieties of semantic roles.

According to the Minimalist Program, Dholuo concatenated verbal extensions are projected as heads since they are incorporated in the verb together with the arguments they introduce to the verb. These heads, as established in the study, are feature driven. The features are introduced to the matrix of the host verb by the extensions and they have to be checked for their interpretation hence a covert movement of the verb holding the features from within the VP to respective heads. In the MP analysis every item constituting a verbal template is projected because Dholuo licenses this. The complexity of Dholuo derived verbs allows the creation of both functional and derivational heads in the MP tree for feature-interpretation and assignment of semantic roles to the arguments introduced by the extension in a verb. The assignment of semantic roles to an argument introduced by an extension is based on the fact that the argument occupies a theta position.

References

- Baker, M. C. (1988). *Theta Theory and the Syntax of Applicative in Chichewa*, in: *Natural Language and Linguistics Theory*. Vol. 6, p. 353-389.
- Blount & Elise, P. B. (1971). *Luo-English Dictionary*. Institute of African Studies, University of Nairobi.

- Carnie, A. (2002). *Syntax: Generative Introduction*. Oxford: Blackwell.
- Carstairs, A. (1992). *Current Morphology*. London: Routledge.
- Chomsky, N. (1965). *Aspects of the Theory of Syntax*. MA: MIT Press.
- Chomsky, N. (1995). *The Minimalist Program*. Cambridge, Mass: MIT Press.
- Cocchi, G. (2008). *Verbal Extensions in Tshiluba*, in: *Lingua* p.75-89.
- Cook, V. J. (Eds) (1988). *Chomsky's Universal Grammar*. Oxford: Blackwell publishers.
- Cook, V. J., & Newson, M. (1996). *Chomsky's Universal Grammar: An Introduction*. Oxford: Blackwell Publishers.
- Gahutu, P. (2012). Tense, Aspect and Modality Systems in Kihavu: A Minimalist perspective. Unpublished PhD Dissertation, Kenyatta University. Nairobi.
- Hornstein, N. (2005). *Understanding Minimalism*. New York: Cambridge University Press.
- Jackendoff, R. S. (1972). *Semantic Interpretation in Generative Grammar*. Cambridge, MA: MIT.
- Jan-Wouter, Z. (1998). *The Minimalist Program*. The Review Article. Cambridge: Cambridge University Press. p. 213-226.
- Jowi, J. O. (2003). *The Constituent Order Typology of Dholuo Verbs: A Government and Binding Theory*. Unpublished PhD Dissertation, Moi University, Kenya.
- Katamba, F. (1993). *Morphology*. United Kingdom: Palgrave.
- Lyons, J. (1977). *Semantics*. Cambridge: Cambridge University Press.
- Martin, H. & Müll-Bardey, T. (2001). *Valence Change*. *HSK- Morphology*. A Handbook on inflection and word formation by G. Booij & C. Lehmann & J. Mugdan. MPI Leipzig & Universität Mainz.
- Matellán, V.A. (2010). *Argument Structure and Syntax-Morphology Interface. A Case Study in Latin & Other Languages*. PhD Dissertation. Universität de Barcelona.
- Mwihaki, A. (2007). *Minimalist Approach to Kiswahili Syntax*. Retrieved on 20th July 2015 from <http://www.ajol.info/index.php/ksh/article/view/file/64852/54207>.
- Ochola, E. (2003). *A Morphosyntactic Analysis of Dholuo Verbal System*. Saarbrücken: Lambert Academic Publishing.
- Okoth, O. D. (1997). *Valence in Dholuo: Towards a Uniform Account of Transitive and Intransitive Construction*. In: Proceedings of Fourth Nilo-Saharan Linguistic colloquium. Helmut Buske Verlag.
- Omondi, L. (1982). *The Major Syntactic Structure of Dholuo*. Berlin: Dietrich Reimer Verlag.
- Onyango, J. A. (2013). *A Semantic Analysis of Dholuo Anaphors in the Simple Declarative Sentence*. Unpublished MA Thesis, University of Nairobi.
- Pollock, J.K. (1989). *Verb Movement, Universal Grammar, and the Structure of IP* in. *Linguistic inquiry*, 20(3): p.365-424.
- Radford, A. (1997). *Syntactic Theory and the Structure of English: A Minimalist Approach*. Cambridge: Cambridge University Press.
- Reinhart, T. (2002). The Theta System-an Overview in: *Theoretical Linguistics*, 28(3)
- Schroeder, H. (2002). *A Word Order in Toposa. An Aspect of Multiple Feature Checking*. PhD Dissertation, University of Nairobi.

- Shibatani, M. (1996). *“Applicatives and Benefactives: a Cognitive Account,”* in: M. Shibatani & S.A Thompson (eds), *Grammatical Constructions: Their Form and Meaning*. Oxford: Oxford University Press.
- Sande, W.O. (2016). A Minimalist Analysis of Dholuo Verbal Extensions. Unpublished Masters Thesis, Jaramogi Oginga Odinga University of Science and Technology.
- Tesnière, L. (1959). *Éléments de syntaxe structural*. Paris: Klincksieck.
- Trask, R. L. (1993). *A Dictionary of Grammatical Terms in Linguistics*. London: Routledge.
- Tucker, A.N. (1994). Creider, C.A. et al (Eds) *A grammar of Kenya Luo (Dholuo)*. Köln: Rüdiger Köppe Verlag.
- Waweru, M.M. (2011). Gikuyu Verbal Extensions: A Minimalist Analysis. Unpublished PhD Dissertation, Kenyatta University, Kenya.
- Williams, E. (1981). *“Argument Structure and Morphology,”* The Linguistic Review vol.1 p. 81-114.